

**Dimmer UP 525/01**
**5WG1 525-2AB01**

## Product and Applications Description



The dimmer UP 525/01 is a dimming actuator (60 mm Ø, depth 60 mm) with additional physical external interface and available mounting hanger for screw mounting to the box mount. EIB sensor modules (e.g. push buttons) can be plugged in the 10 pin PEI interface. The bus line is connected via the bus connection block and the load circuits are connected via screwless bus connection blocks.

The dimmer UP 525/01 can switch and dim incandescent lamps, high voltage halogen lamps, low voltage halogen lamps with intermediate conventional transformers.

### Note

The dimmer UP 525/01 is a phase interval dimmer.

Several tasks are available for the dimmer, i.e. the dimmer UP 525/01 consists of the device (hardware) and its application programs (software).

Several tasks can be set in parameter list e.g. switching on and off low voltage halogen lamps, increasing and decreasing their light intensity or setting them to a specified light intensity value.

With the ETS (EIB Tool Software) the application program is selected, its parameters and addresses are assigned appropriately, and downloaded to the dimmer UP 525/01 .

## Application Programs

The application programs of the dimmer UP 525/01 consist of two elements: the actuating and the sensor program element. The tasks actuating program element are the same, only the sensor program element is different.

The tasks of the actuating program element are:

- single dimmer for on/off, dim, set value
- allows switching on bus voltage recurrence
- dimming range adjustable
- dimmed value when switching on adjustable
- allows state to be read via bus
- allows dimming and set-value operations while switched off without having to switch on
- establishes light intensity specified in the set-value mode optionally directly or via dimming.

### 20 A1 Actuator-BCU-Dimmer 903002

- sensor element
  - allows switching, shutter control or dimming
  - allows to call / program scenes
  - each rocker depression point allows to send 8-bit value
  - LEDs always off or used as state display or orientation light

### 20 A1 Actuator-BCU-Dimmer 903402

- sensor element
  - single push button
  - allows switching, shutter control or dimming
  - allows to call / program scenes
  - each rocker depression point allows to send 8-bit value
  - LEDs always off or used as state display or orientation light

### 20 A1 Actuator-BCU-Dimmer 903502

- sensor element
  - double push button
  - allows switching, shutter control or dimming
  - allows to call / program scenes
  - each rocker depression point allows to send 8-bit value
  - LEDs always off or used as state display or orientation light

## Dimmer UP 525/01

5WG1 525-2AB01

**20 A1 Actuator-BCU-Dimmer 903602**

- sensor element
  - push button 4-fold
  - allows switching, shutter control or dimming
  - allows to call / program scenes
  - each rocker depression point allows to send 8-bit value
  - LEDs always off or used as state display or orientation light

**20 A1 Actuator-BCU-Dimmer 903802**

- sensor element
  - push button 4-fold
  - allows switching, shutter control or dimming
  - allows to call / program scenes
  - each rocker depression point allows to send 8-bit value
  - LEDs always off or used as state display or orientation light

**20 A1 Actuator-BCU-Dimmer 903902**

- sensor element
  - push button 1-fold
  - allows switching, shutter control or dimming
  - allows to call / program scenes
  - each rocker depression point allows to send 8-bit value
  - orientation light always off or used

**20 A1 Actuator-BCU-Dimmer 903A02**

- sensor element
  - push button 2-fold
  - allows switching, shutter control or dimming
  - allows to call / program scenes
  - each rocker depression point allows to send 8-bit value
  - orientation light always off or used

**20 A1 Actuator-BCU-Dimmer 903C02**

- sensor element
  - push button 1-fold
  - allows switching, shutter control or dimming
  - allows to call / program scenes
  - each rocker depression point allows to send 8-bit value
  - LEDs always off or used as state display or orientation light

**20 A1 Actuator-BCU-Dimmer 903D02**

- sensor element
  - push button 2-fold
  - allows switching, shutter control or dimming
  - allows to call / program scenes
  - each rocker depression point allows to send 8-bit value
  - LEDs always off or used as state display or orientation light

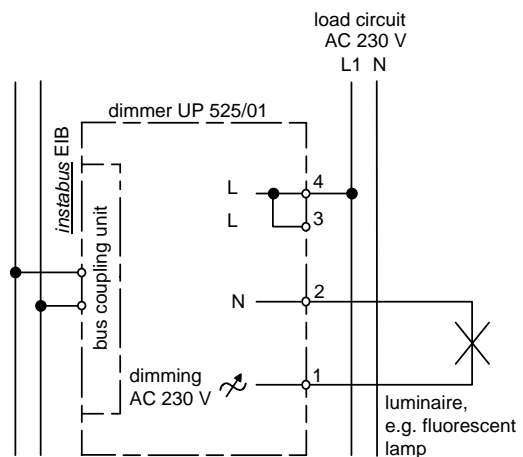
**Example of Operation****Installation Instructions**

- The device may be used for permanent interior installations in dry locations within box mounts.

**WARNING**

- The device must be mounted and commissioned by an authorised electrician.
- A safety disconnection of the device must be possible.
- There mustn't be any switching actions at the load output.
- The device may be mounted to switch and socket combination box mounts provided VDE-certified devices are used exclusively.
- The prevailing safety rules must be heeded.
- The device must not be opened. A device suspected faulty should be returned to the local Siemens office.

**Dimmer UP 525/01****5WG1 525-2AB01****Technical Specifications****Power supply**

via bus cable and 230 V mains

**230 V-Supply connection**

- rated voltage: AC 230 V, 50 Hz
- rated current: 1,1 A
- no-load current: approx. 5,5 mA
- no-load power input: approx. 1,3 VA
- no-load power loss: approx. 0,5 W

**Short-circuit protection**

Electronic protection that switches the device down for one minute when it detects a short-circuit and tries to switch the device on automatically to the actual set value in a time cycle of 1 minute.

**Overload protection**

Electronic protection switching the dimmer down for at least one minute when exceeding the permitted maximum temperature due to overload and sets the actual set value after cooling down automatically.

**Load output**

- number: 1 output
- rated voltage: 230 V AC, 50 Hz
- rated current: 1,1 A
- maximum power consumption of devices connected at 35°C ambient temperature:
  - incandescent lamp: 500 W
  - high voltage halogen lamps with intermediate electronic transformers: 20...250 W
  - low voltage halogen lamps with intermediate electronic transformers: 20...250 W
- maximum power consumption of devices connected in relation to the ambient temperature:

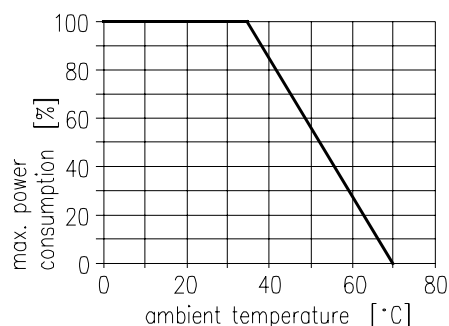
**Characteristic at mains voltage failure**

The dimmer resumes the actual switching condition and light intensity value saved in the bus coupling connection after mains voltage recurrence.

**Characteristic at bus voltage failure**

switch-off (cannot be set in the parameter list)

**Characteristic at bus voltage recurrence**

set in parameter list according to application program

**Control elements**

1 learning button: for switching between normal operating mode and addressing mode

**Display elements**

1 red LED: for monitoring bus voltage and displaying mode, selected with the learning button

**Connections**

- load circuit, physical:
  - strip insulation for 9 ... 10 mm
  - permissible conductor types/cross sections:
    - 0,5 ... 2,5 mm<sup>2</sup> single core or flexible conductor, 8 mm ultrasonically compacted
    - 0,5 ... 2,5 mm<sup>2</sup> flexible conductor with terminal pin, crimped on gas tight
    - 0,5 ... 1,5 mm<sup>2</sup> flexible conductor with connector sleeve
    - 1,0 and 1,5 mm<sup>2</sup> plain flexible conductor
- load circuit, electrical:
  - plain flexible conductor, min. 1 mm<sup>2</sup>: current carrying capacity max. 6 A
  - flexible conductor with terminal pin, crimped on gas tight, min. 1,5 mm<sup>2</sup>: current carrying capacity max. 10 A
  - all other conductors, min. 1,5 mm<sup>2</sup>: current carrying capacity max. 10 A

**WARNING**

When looping through the L-conductor (L-connection block), take care that the maximum connection current of 10 A (as governed by the maximum permissible printed conductor load) is not exceeded!

- bus line: pressure contacts on data rail 0,6...0,8 mm Ø single core
- 10-pin socket (PEI): for connecting application units

**Physical specifications**

- housing: plastic
- dimensions:
  - spacer dimensions (W x H): 71 x 71 mm
  - mounting depth: 39 mm
- weight: approx. 80 g (mounting hanger included)
- fire load: approx. 1020 kJ ± 10 %
- installation: mounting in box mounts  
60 mm Ø, depth 60 mm

**Electrical safety**

- fouling class (according to IEC 664-1): 2
- protection (according to EN 60529): IP 20
- overvoltage class (according to IEC 664-1): III
- bus: safety extra low voltage SELV DC 24 V
- device complies with  
EN 50090-2-2 and EN 60669-2-1

**Reliability**

- rate of failure: 565 fit at 40°C

**Electromagnetic compatibility**

complies with  
EN 50081-1; EN 50082-2, EN 60669-2-1  
and EN 50090-2-2

**Environmental specifications**

- climatic conditions: EN 50090-2-2
- ambient temperature operating: - 5 ... + 45 °C
- ambient temperature non-op.: - 25 ... + 70 °C
- relative humidity (non-condensing): 5 % to 93 %

**Certification**

EIB certificate

**CE norm**

complies with the EMC regulations (residential and functional buildings), and low voltage regulations

**Location and Function of the Display and Operator Elements**

Figure 1: Location of the display and operator elements

- A1 LED for indicating normal operate mode(LED off) or addressing mode (LED on); returns to normal operating mode automatically after receiving the physical address
- A2 Learning button for switching between normal operating mode and addressing mode and for receiving the physical address
- A3 Physical external interface (PEI) for plugging-in the application unit
- A4 Long slots for attaching the application unit on the box mount
- A5 Slots for attaching the application unit via slide guidance and fastening clamps
- A6 Thread for the mounting screws (for additional fastening of the application unit, e.g. theft protection)
- A7 Type label
- A8 Screwless plug-in connection blocks with verification tap to connect the load circuits
- A9 Bus connection block for single core conductors with 0,6...0,8 mm Ø
- A10 Snap-on cover for bus line and single bus wires
- A11 clamping slots for anchoring the bus lines

**Dimmer UP 525/01****5WG1 525-2AB01****Mounting and Wiring**

The dimmer UP 525/01 is built into box mounts (60 mm Ø, depth 60 mm) via a screw mount. It is connected to the bus line via the bus connection block 193 (screwless plug-in connection blocks for single core conductors). The application units (such as push buttons) are slipped onto the binary output via guiding and fastening springs and, depending on the type, tightened by screws.

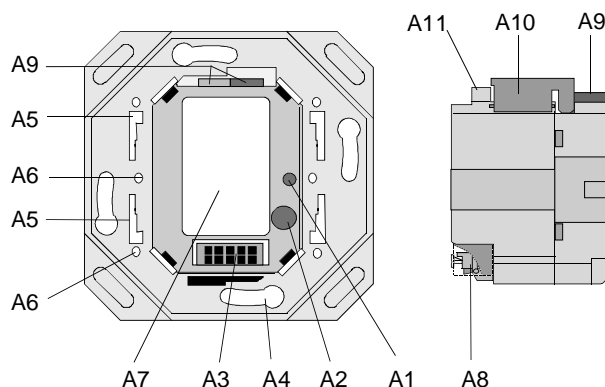
**Note**

The dimmer UP 525/01 must be mounted placing the physical external interface (PEI) at the bottom (figure 2) ensuring that the application units designated to be plugged on the PEI are mounted in the correct operational position. To guarantee a permanently ensured contact it is recommended to use only application units with mounting screws.

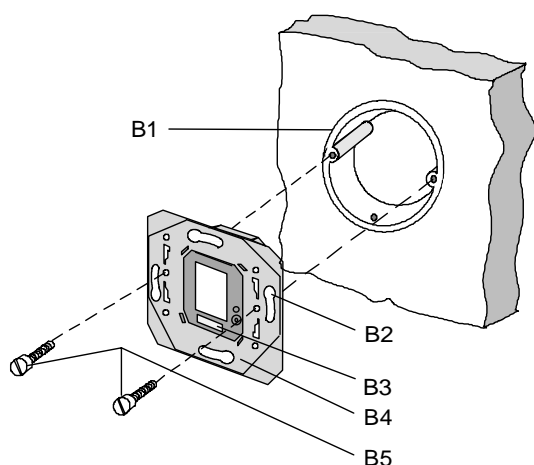

Figure 2: Mounting the dimmer UP 525/01

- B1 box mount (60 mm Ø, according to DIN 49073)
- B2 mounting slots
- B3 physical external interface (PEI)
- B4 dimmer UP 525/01
- B5 mounting screws

**Slipping on/off bus connection blocks (Figure 3)**

The bus connection block (C2) is situated at the top of the device (C3). It consists of two components (C2.1 and C2.2) with four terminal contacts each. Take care not to damage the two test sockets (C2.3) by accidentally connecting them to the bus cable or with the screw-driver (e.g. when attempting to unplug the bus connection block).

**Slipping off bus connection blocks (Figure 3)**

- Put the screw-driver between the cover (C1) and the dimmer (C3) from the side and lever out the cover.
- Carefully put the screw-driver to the wire-inserting slit of the bus connection block's grey component (B3.3) and pull the bus connection block (B3) from the built-in device.

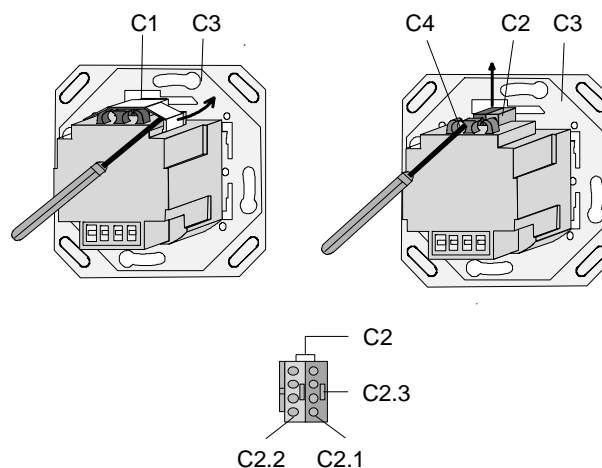

Figure 3: Slipping on/off bus connection blocks

**Note**

Don't try to remove the bus connection block from the bottom side! There is a risk of shorting-out the device!

**Connecting bus cables (Figure 4)**

- The bus connection block (D2) can be used with single core conductors Ø 0,6 ... 0,8 mm.
- Remove approx. 25-35 mm of the insulation from the sheathing of the bus cable (D1).
- Remove the end of the conductor's (D2.4) insulation and plug it into the bus connection block (D2) (red = +, grey = -).

Slipping on bus connection blocks (Figure 3)

- Slip the bus connection block (C2) onto the guide slot of the dimmer (C1) and
- press the bus connection block (C2) down to the stop.
- press the sheathing of the cut-off insulation bus line projecting >3mm into the open clamping slot (C4). If a further bus line shall be connected break out the closed clamping slot with a screw-driver and press it into the clamping slot as described above. Press the single bus wires into the recess below the bus connection block and snap on the cover (C1)

Disconnecting bus cables (Figure 4)

- Unplug the bus connection block (D2) and remove the bus cable conductor (D2.4) while simultaneously wiggling it.

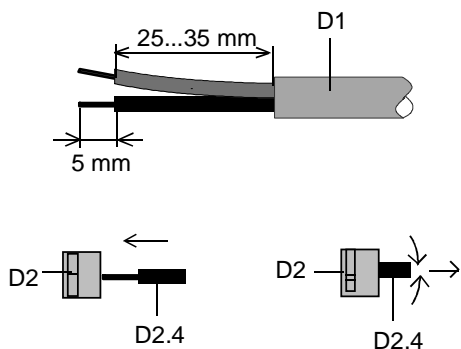

Figure 4: Slipping on/off bus connection blocks

Connecting load circuits (Figure 5)

- The load circuits are connected via screwless plug-in terminals (E1).
- Remove approx. 9...10 mm of insulation from the wire (E1.1) and plug it into the terminal (E1).

Conductor cross sections:

- load circuit, physical: strip insulation for 9 ... 10 mm permissible conductor types/cross sections:
  - 0,5 ... 2,5 mm<sup>2</sup> single core or flexible conductor, 8 mm ultrasonically compacted
  - 0,5 ... 2,5 mm<sup>2</sup> flexible conductor with terminal pin, crimped on gas tight
  - 0,5 ... 1,5 mm<sup>2</sup> flexible conductor with connector sleeve
  - 1,0 and 1,5 mm<sup>2</sup> plain flexible conductor

Disconnect load circuits (Figure 5)

- Press the terminal interlocking (F1.2) of the block (F1) with a screw-driver and
- remove the wire (F3) from the block (F1).

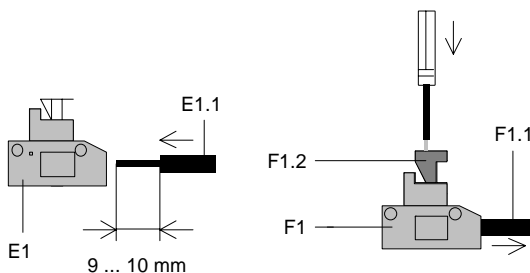

Figure 5: Connecting/disconnecting load circuit

**Dimension Diagram**

Dimensions in mm

