

## Load switch N 510/04 5WG1 510-1AB04 4 x 230 V AC / 16 A

Issued: March 2003

### Product and Applications Description

The load switch N 510/04 is a N-system DIN-rail mounted device. Via its four outputs it can switch four separate groups of electric devices.

The power supply of the load switch N 510/04 is provided by the bus (i.e., it requires no additional power supply).

The outputs may be operated manually via slide switches. These switches also show the actual switching state (when switching manually as well as when switching via the bus).

Each of the outputs (relays) can be assigned various tasks depending on the application program used, i.e. the load switch N 510/04 consists of the device (hardware) and its application programs (software).

Appropriate application programs are available for the different tasks the load switch N 510/04 can handle; e.g. for non-delayed on and off switching.

With the ETS (EIB Tool Software) the application program is selected, its parameters and addresses are assigned appropriately, and downloaded to the load switch N 510/04.

### Additional Informations

<http://www.siemens.de/gamma>

### Example of Operation

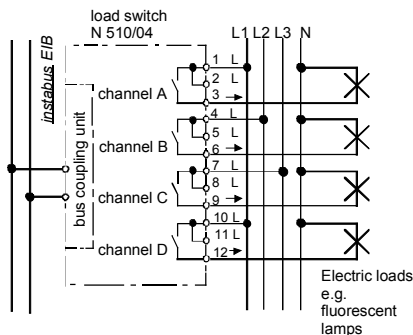

### Technical Specifications

#### Power supply

via bus line  
Data rail and / or bus connection blocks

#### Outputs

- number: 4 (bistable relays, volt free contacts)
- rated voltage: AC 230 V, 50 ... 60 Hz
- rated current: 16 A resistive load
- switching current at AC 230 V: 0,01...16 A resistive load
- switching characteristic: set in parameter list according to application program

#### Connections

- load circuit, physical:
  - strip insulation for 8 ... 9 mm
  - permissible conductor types/cross sections:
    - 0,5 ... 4 mm<sup>2</sup> single core
    - 0,5 ... 2,5 mm<sup>2</sup> flexible core
- load circuit, electrical:
  - plain flexible conductor, min. 1 mm<sup>2</sup>: current carrying capacity max. 6 A
  - flexible conductor with terminal pin, crimped on gas tight, min. 1,5 mm<sup>2</sup>: current carrying capacity max. 10 A
  - all other conductors, min. 1,5 mm<sup>2</sup>: current carrying capacity max. 16 A

### WARNING

When looping through the L-conductor (connection blocks 1 and 2, 4 and 5, 7 and 8, 10 and 11) take care that the maximum connection current of 16 A (as governed by the maximum permissible printed conductor load) is not exceeded!

- bus line:
  - pressure contacts on data rail
  - screwless bus connection block 0,6...0,8 mm Ø single core remove approx. 5mm of isolation

#### Physical specifications

- N-system DIN-rail mounted device, width: 4 SUs (1 SU = 18 mm)
- weight: approx. 280 g

#### Electrical safety

- Type of protection (in acc. with EN 60529): IP 20

#### Environmental specifications

- ambient temperature operating: - 5 ... + 45 °C
- ambient temperature non-op.: - 20 ... + 70 °C
- relative humidity (non-condensing): 5 % to 93 %

### Location and Function of the Display and Operator Elements

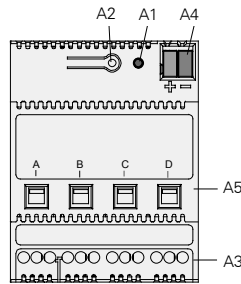

Diagram 1: Location of the display and operator elements

- A1 LED for indicating normal operating mode (LED off) and addressing mode (LED on); upon receiving the physical address the device automatically returns to normal operating mode.
- A2 Learning button for switching between normal operating mode and addressing mode for receiving the physical address.
- A3 Screw blocks for connecting load circuits;
- A4 Screwless bus connection block;
- A5 Slide switch for manual operation and for displaying the switching position.  
Slide in upper position: relay contact closed  
Slide in lower position: relay contact open

#### Important hint:

The manual operation of the sliding switches is only designated as an emergency operation. There is no telegram downloaded to the bus and the changed position is not recognised by the bus controller. In case of bus voltage failure/recurrence even the switching conditions of manually controlled relays resume the condition set in parameter list.

### Mounting and Wiring

- The device may be used for permanent interior installations in dry locations within distribution boards or small casings with DIN rail EN 60715-TH35-7,5

### WARNING

- The device may be built into distribution boards (230/400 V) together with appropriate VDE-devices
- The device must be mounted and commissioned by an authorised electrician.
- A safety disconnection of the device must be possible. Especially if the device is connected to different phases.
- Free DIN rail areas with sticked-in data rail must be covered with covers, order no. 5WG1 192-8AA01.
- The prevailing safety rules must be heeded.
- The device must not be opened.
- For planning and construction of electric installations, the relevant guidelines, regulations and standards of the respective country are to be considered.

If the connection is established via bus connection block (data rail not installed) the data rail connection system has to be covered with the enclosed insulation hood after removing the location clip e.g. with a screw driver to guarantee a sufficient insulation from the DIN rail.  
If the load switch N 510/04 is installed the conventional adapter is not necessary (also for other DIN-rail devices). The bus voltage is downloaded from the bus connection block to the data rail.

#### Removing the location clip (Diagram 2)

- The location clip (D3) surrounds the contact system (D2) on the back side of the load switch N 510/04 (D1).
- Insert the screw driver between the DIN-rail device (D1) and the location clip (D3) and remove the location clip.

#### Inserting the insulation top (Diagram 2)

- Put the insulation top (D4) onto the contact system and click it into place by a slight pressure.

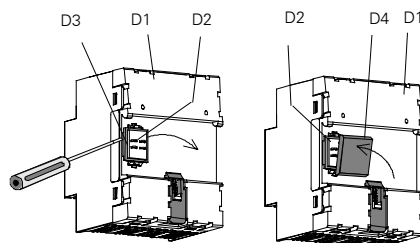

Diagram 2: Covering the contact system

### General Notes

- Any faulty devices should be returned to the local Siemens office.
- If you have further questions about the product, please contact our Technical Support:

+49 (0) 180 50 50-222  
+49 (0) 180 50 50-223  
[adsupport@siemens.com](mailto:adsupport@siemens.com)