

MDT Universal Interface 2/4/6-fold, flush mounted

| Version | | |
|-------------|----------------------------|--|
| BE-02001.02 | Universal Interface 2-fold | Flush mounted, to connect potential free contacts, with LED output |
| BE-04001.02 | Universal Interface 4-fold | Flush mounted, to connect potential free contacts, with LED output |
| BE-06001.02 | Universal Interface 6-fold | Flush mounted, to connect potential free contacts, with LED output |
| BE-02230.02 | Universal Interface 2-fold | Flush mounted, for 230VAC signals |

The MDT Universal Interface detects status changes at the inputs and triggers KNX telegrams depending on his parameterizations. You can connect conventional push-buttons or auxiliary contacts (e.g. door and window contacts) to the device. The length of connection cables is 22cm. Each input can be set as a LED output and drive a low current LED.

The MDT Universal Interface includes four integrated logical modules to implement logical operations and logical control. These logical modules interpret all the inputs plus two external objects. So you can easily create KNX/EIB telegrams which are required in daily practice (e.g. fault telegrams or „all windows closed“).

Each input is parameterized individually via ETS. The device provides extensive functions like switching of lighting, operation of blinds and shutters, counting of pulses, debounce time, contact typ and telegram rate limitation. The command for rising and falling edge can be defined independently and with the block communication object each channel can be blocked or released. The logic module can release two telegrams after receiving a trigger signal from the inputs.

The MDT Universal Interface is a flush mounted device to be inserted in a installation box or behind a push button or switch. It has to be installed in dry rooms.

For project design and commissioning of the MDT Universal Interface it is recommended to use the ETS. Please download the application software at www.mdt.de/Downloads.html

BE-02001.02

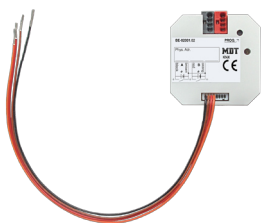

BE-04001.02

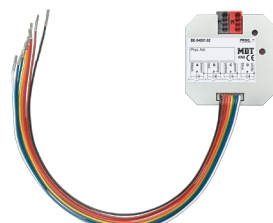

BE-06001.02

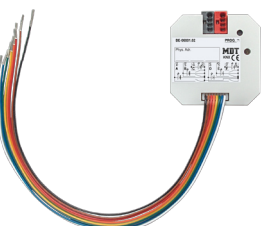

BE-02230.02

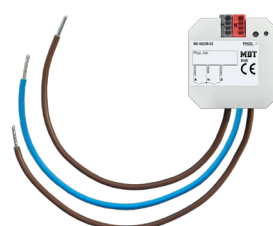

- Production in Germany, certified according to ISO 9001
- To connect **push-buttons or window/auxiliary contacts**
- Each input can be set as 1,5mA output for low current LED (Not with BE-02230.01)
- **New multi touch function, sends up to 4 values/DPTs on the same or diffrent objects**
- **Innovative group control with long/extra long button press**
- **4 integrated logical modules**, e.g. interpretation of the inputs (e.g. windows closed or sending second object)
- Telegram rate limitation
- NO or NC contact operation, adjustable length of button push
- Dimming and shutter function for 1 and 2 button operation
- Forced setting function for each output
- **Short/long button push with 2 objects**
- Counting of pulses
- Cyclical sending of contact state adjustable
- Flush mounted installation (length of connection cables: 22cm)
- Dimensions (W x H x D): 41mm x 41mm x 12mm
- Integrated bus coupling unit
- 3 years warranty

| | | | |
|---------------------------------------|---|---------------------|--|
| Technical Data | BE-02001.02 BE-04001.02 BE-06001.02 | BE-02230.02 | |
| Number of channels | 2/4/6 | 2 | |
| Contact voltage | 3,3VDC* internal | 230VAC | |
| Switching threshold typ. | -- | 165VAC | |
| LED current per channel | ~1mA | -- | |
| Specification KNX interface | TP-256 | TP-256 | |
| Available application software | ETS 5 | ETS 5 | |
| Permitted wire gauge | | | |
| KNX busconnection terminal | 0,8mm Ø, solid core | 0,8mm Ø, solid core | |
| Power Supply | KNX bus** | KNX bus | |
| Power consumption KNX bus typ. | <0,25W | <0,25W | |
| Permitted input cable length | 10m | 100m | |
| Operation temperature range | 0 to + 45°C | 0 to + 45°C | |
| Enclosure | IP 20 | IP 20 | |
| Dimensions UP (W x H x D) | 41mm x 41mm x 12mm | 41mm x 41mm x 22mm | |

* There is no galvanic separation between contact voltage and KNX bus voltage.

** If any 230V cables are in the vicinity, make sure to maintain the distances to them specified as in the applicable standards and regulations. Never install the device in a flush mounted box together with 230V cables.

Exemplary circuit diagram BE-02001.02

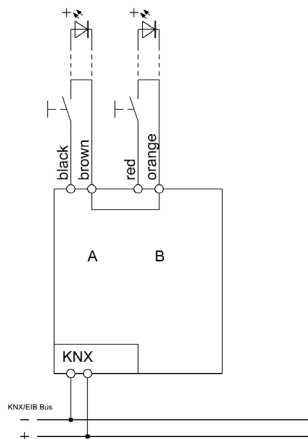

Exemplary circuit diagram BE-06001.02

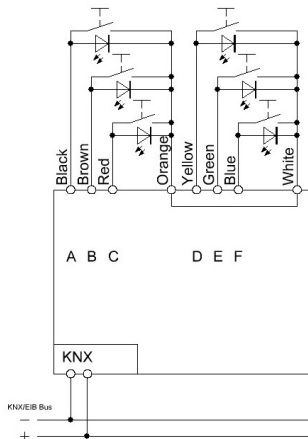

Exemplary circuit diagram BE-04001.02

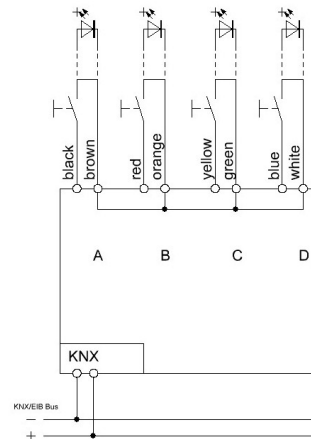

Exemplary circuit diagram BE-02230.02

