

KNX Sensor for two Analog Signals, SK01-S8-AN2

The KNX Sensor for two analog signals is a sensor/controller from the S8 product series which measures two analog Voltage values in the range of 0 to a maximum of 12 volts. The sensor / controller has two ports, each with a ground, a signal input and a supply voltage pin (e.g. for a sensor). The device SK01-S8-AN2 has an integrated KNX bus coupler and required, depending on the measurement electronics and configure, an additional voltage between 9 and 30 volts. The transducer with the bus coupler is enclosed in a durable, sealed, glass ball-reinforced plastic casing which fulfils protection degree IP65.

In the application software there are several controllers available (two-position or PI controller with continuous or pulsed output) separately for both channels. Additional functions include the display of upper and lower thresholds and switching between the set point and threshold.

The sensor is configured by ETS (KNX Tool Software) and the application program. Controlling functions such as signal threshold and other adjustments are parameterized by the ETS (KNX Tool Software).



Measuring Amplifier: Input range:	adjustable from 0-2 V to 0-12 V
Measuring Range:	0 to maximal 12 V
Ambient Temperature Transducer:	-20 ... +80°C
Protection System Casing Transducer:	IP65

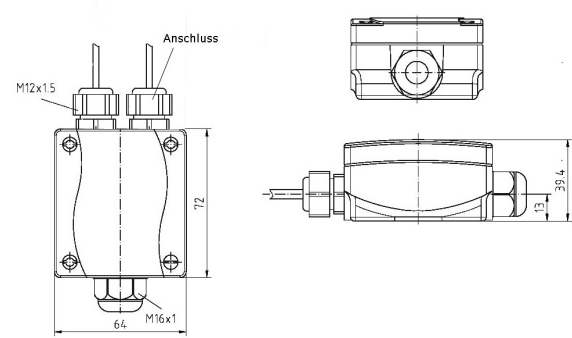

Technische Daten	SK01-S8-AN2
Measured Data:	Voltage
Sending Options	No sending, periodic sending, sending when change occurs
Parameter	Periodic sending with variable cycle duration, sending when change occurs with variable hysteresis
Types	1-Byte-unsigned Integer, 1-Byte-signed Integer, 2-Byte-unsigned Integer, 2-Byte-signed Integer, 2-Byte-Float, 4-Byte-unsigned Integer, 4-Byte-signed Integer, 4-Byte-Float
Controller Modes :	Two-position controller static, two-position controller pulsed, PI controller static, PI controller pulsed (PWM)
Parameter Two-Position Controller Static	Set point, differential gap, controller
Parameter Two-Position Controller Pulsed	Set point, differential gap, controller, cycle duration, threshold pitch
Parameter PI Controller Static	Set point, reset time, proportional factor, controller
Parameter PI Controller PWM	Set point, reset time, proportional factor, controller, cycle duration, threshold pitch
Lock Function:	Parameter driven lock and release
Controller for Control Variable Output:	Switching output (1/0), 1-Bit
	Switching output pulsed, parameter driven duty cycle and cycle duration, 1 Bit
	Switching output pulsed, parameter driven cycle duration, duty cycle variable driven (PWM) with threshold pitch, 1 Bit
	Control variable static, 1-byte
Control Variable Periodic Sending:	None or 10-250 seconds parameter driven
Threshold:	Upper threshold, lower threshold
Auxiliary Quantities:	Set point, lower threshold, upper threshold
Bus Power Failure:	Saving changed auxiliary quantities is parameter driven
Calibration:	Factory setting: 0-10 V
Ambient Temperature:	Operation -20...+80°C (transducer)
Ambient Temperature Humidity:	0...95% rH not condensated
Operating Voltage:	EIB/KNX bus voltage 21-32V DC
Power Consumption ca.:	Depending on sensor and configuration
Auxiliary Supply:	Is recommended, however, depending on sensor and configuration
Bus Coupler:	Integrated
Start-up with ETS:	ARC_SK08_v7.pr5 Product: SK01-S8-AN2
Circuit Points:	EIB-2-pole clamps (red/black)
Protection Class:	IP65
Assembly Type Transducer:	Assembly with 2 screws finery
Casing Transducer:	Plastic grey
Casing Dimensions:	72 mm x 64mm x 39,4 mm (L x H x D)
Article Number:	30806200

Start-up:

The KNX Sensor is set up by using the ETS (KNX Tool Software) and the applicable application program. The sensor is delivered unprogrammed. All functions will be programmed and parameterized with ETS. Please read the ETS instructions.

Assembly:

The sensor SK01-S8-AN2 is intended for outdoor use. It fulfils protection class IP65. The sensor is attached to the wall with two screws.

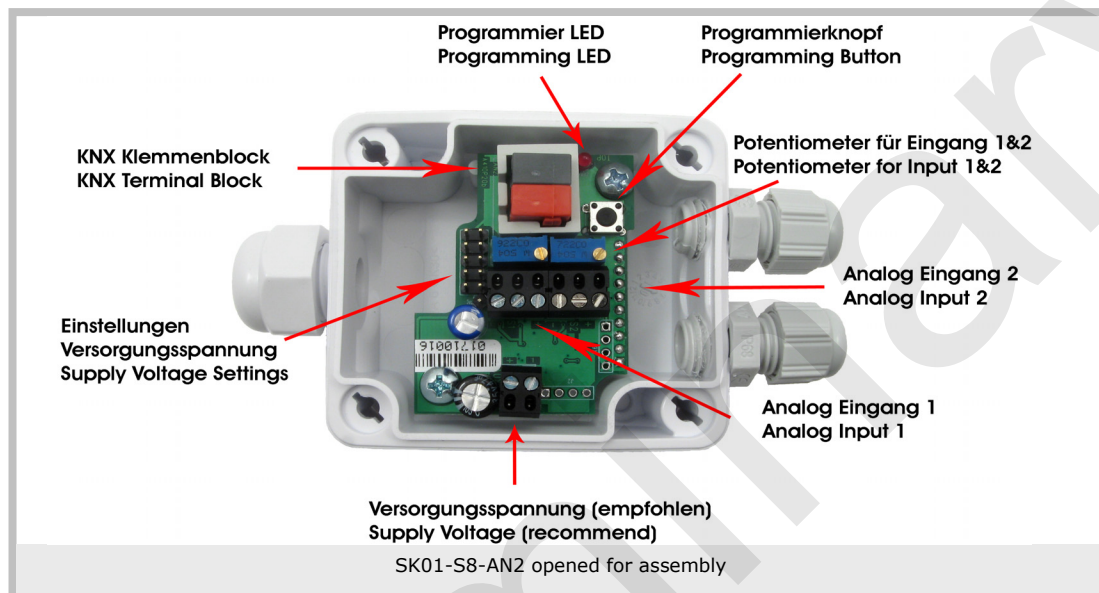

Analog Input 1 and 2:	
+	Secondary supply voltage output. The voltage can be set via jumper, details see the section "Secondary supply voltage".
S1 & S2	Analog input. The possible input range is from 0-2 V to 0-12 V and can be set for each channel separately with the potentiometer behind the port. For details see the section "Input Adjustment".
-	Secondary Ground (ground)

Supply Voltage (9-30 V):	
	This supply voltage is required when KNX bus and measurement electronics should operate isolated or the supply to the "+" Pin in pure KNX bus operation is not sufficient. For details, see the section "Secondary supply voltage".

The transducer lid is opened by loosening the screws.

The cables of the measured signals are connected to the illustrated place in the Figure. Run the KNX bus cable through the housing openings (PG Connection), after the sensor was attached to the wall or ceiling. Pull the KNX bus terminal block from the device. After connecting the cable to the bus terminal block, this may again be attached to the sensor assembly. After programming the lid is sealed with the cover screws. In order to comply with protection class IP65, the supplied gasket is carefully inserted in the lid.

→ Be careful not to damage the electronics with tools and cable heads.

Secondary supply voltage:

The dual row connector, for setting the secondary supply voltage, will be always represented by the image in a visible model on the left side and will be aligned exactly as in the image on the right.

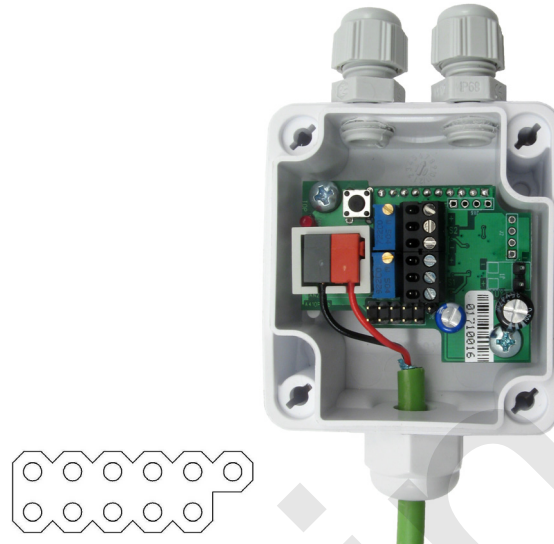

Figure 1: left: row connector model right: equally oriented unit

If in the following sections a connected supply voltage is mention, the device has to be configured like in Figure 2, so an additional supply voltage (0-30 V) has to be connected to the right pinhead.



Figure 2: connected supply voltage (9-30 V)

In the following two tables will be described witch settings for the secondary power supply are possible. The settings of the jumpers affects both "+" pins in the same way, a separate adjustment is **not** possible.

Electrically isolated (recommend):

In this mode, the measurement and KNX page is completely isolated.

Benefits include lower susceptibility to interference and high power supply available for external sensors.

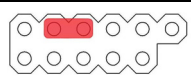
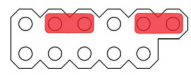
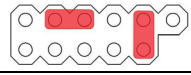
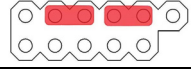
row connector model	Description	Supply voltage connected
	Factory setting. There is no additional voltage at the "+" Pin.	YES
	The supply voltage is connected to the "+" Pin.	YES
	There are 5 V at the "+" Pin and it can be taken at most 200 mA for both outputs together.	YES
	There are 3.3 V at the "+" Pin and it can be taken at most 100 mA for both outputs together.	YES

Not Electrically isolated:

In this mode, measurement and KNX parts are not isolated.

Disadvantages are higher susceptibility and lower available current.

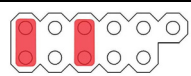
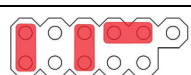
row connector model	Description	Supply voltage connected
	There is no additional voltage at the "+" Pin.	NO
	There are 3.3 V at the "+" pin and it can be taken at most 5 mA for both outputs together.	NO

Input Adjustment:

According to factory settings both input range are set to 0-10 V. If you need other then this the ranges can be set between 0-2 V and 0-12 V via the potentiometer behind each channel connector pinhead, separately for each one.

The default settings in the ETS application are set at levels so the maximum measurable voltage (set by potentiometer (to factory settings 10 V)) corresponds to a 10 as 2 byte float on the KNX bus.

Now if you want a range of 0-12 V you should proceed as following:

1. Connect device to KNX Bus.
2. Apply an 12 V reference voltage between the sensor pin (S1 and / or S2), and "-" Pin.
3. Open ETS with SK01-AN2 application (default settings in the parameters).
4. Select desirable channel and read it.
5. Now turn the potentiometer until the value 10 is read.

For other value ranges it is exactly the same procedure only the right reference voltage has to be selected i.e. for an range of 0-3 V the reference voltage have to be 3V.

The values available on the KNX Bus can be retouched via Parameter settings so for Example measured values between 0 an 10 V corresponds to an KNX value Range of -2.5 to 2.5.

In Case of Bus Voltage Recurrence:

All changes made using the help key for the KNX/EIB bus are saved if the device has been correctly parameterized. The controller and outputs start with the current values. The ETS parameter settings are saved.

Discharge Program and Reset Sensor:

Should the sensor crash due to a programming malfunction, the previous project can be deleted by pressing the programming button. Hold the programming button down while connecting the EIB bus clamp and wait until the programming LED display appears. This will take 5 – 10 seconds. Any calibrations undertaken will be lost.

Imprint:

Publisher: Arcus-EDS GmbH, Rigaer Str. 88, 10247 Berlin

Responsible for Content: Hjalmar Hevers, Reinhard Pegelow

Reprints, including partial reprints, can be made only with expressed permission from Arcus-EDS GmbH. This information is the best to our knowledge and is without guarantee. We reserve the right to make any technical as well as price changes at any time.

Accountability:

The selection of devices and the determination of the suitability of the devices for a specific purpose lie fully in the hands of the said buyer. For this we give no guarantee and do not accept accountability. The data in the catalogue and data sheets do not promise special properties, but instead are derived from experience and measurements. Arcus excludes responsibility for damage done on the part of the customer due to improper operation/projecting or malfunctions. On the contrary, the operator/projector has to make sure that improper operation, and projection and malfunctions do not lead to any further damage.

Safety Guidelines:

Attention! Installing and assembling electrical devices must only be done by an electronics specialist. The customer should be aware of and adhere to the safety guidelines of VDE, TÜV and the appropriate energy provider. Our guarantee does not include defects and damage caused by improper use or non-compliance of operating instructions.

Warranty:

We provide a warranty as required by law. Please contact us in case of malfunction and send the device with a full description of the fault to the address below.

Manufacturer:



Incorporated Trademarks:

 The CE Trademark is an inofficial market trademark used exclusively by authorities and provides no warranty of properties.



Incorporated trademark of Konnex Association